

Rolling bearings — Accessories for sleeve type linear ball bearings

**Part 1: Boundary dimensions and
tolerances for series 1 and 3**

ICS 21.100.20

National foreword

This British Standard is the UK implementation of ISO 13012-1:2009. It supersedes BS ISO 13012:1998 which is withdrawn.

The UK participation in its preparation was entrusted to Technical Committee MCE/7, Rolling bearings.

A list of organizations represented on this committee can be obtained on request to its secretary.

This publication does not purport to include all the necessary provisions of a contract. Users are responsible for its correct application.

Compliance with a British Standard cannot confer immunity from legal obligations.

This British Standard was published under the authority of the Standards Policy and Strategy Committee on 31 August 2009

© BSI 2009

ISBN 978 0 580 59014 6

Amendments/corrigenda issued since publication

Date	Comments

INTERNATIONAL
STANDARD

ISO
13012-1

First edition
2009-02-01

**Rolling bearings — Accessories for
sleeve type linear ball bearings —**

Part 1:

**Boundary dimensions and tolerances for
series 1 and 3**

Roulements — Accessoires pour douilles à billes linéaires —

*Partie 1: Dimensions d'encombrement et tolérances pour les séries 1
et 3*



Reference number
ISO 13012-1:2009(E)

PDF disclaimer

This PDF file may contain embedded typefaces. In accordance with Adobe's licensing policy, this file may be printed or viewed but shall not be edited unless the typefaces which are embedded are licensed to and installed on the computer performing the editing. In downloading this file, parties accept therein the responsibility of not infringing Adobe's licensing policy. The ISO Central Secretariat accepts no liability in this area.

Adobe is a trademark of Adobe Systems Incorporated.

Details of the software products used to create this PDF file can be found in the General Info relative to the file; the PDF-creation parameters were optimized for printing. Every care has been taken to ensure that the file is suitable for use by ISO member bodies. In the unlikely event that a problem relating to it is found, please inform the Central Secretariat at the address given below.



COPYRIGHT PROTECTED DOCUMENT

© ISO 2009

All rights reserved. Unless otherwise specified, no part of this publication may be reproduced or utilized in any form or by any means, electronic or mechanical, including photocopying and microfilm, without permission in writing from either ISO at the address below or ISO's member body in the country of the requester.

ISO copyright office
Case postale 56 • CH-1211 Geneva 20
Tel. + 41 22 749 01 11
Fax + 41 22 749 09 47
E-mail copyright@iso.org
Web www.iso.org

Published in Switzerland

Contents

Page

Foreword.....	iv
Introduction	v
1 Scope	1
2 Normative references	1
3 Terms and definitions	2
4 Symbols	3
4.1 Closed and adjustable flangeless housings for series 1 sleeve type linear ball bearings	3
4.2 Closed and adjustable flanged housings for series 3 sleeve type linear ball bearings	3
4.3 Open flanged housings for series 3 sleeve type linear ball bearings	4
4.4 Closed and adjustable flangeless housings for series 3 sleeve type linear ball bearings	4
4.5 Open and open adjustable flangeless housings for series 3 sleeve type linear ball bearings	4
4.6 Standard height shaft support rails for series 3 sleeve type linear ball bearings	5
4.7 Low height shaft support rails for series 3 sleeve type linear ball bearings	5
4.8 Flanged shaft support blocks for series 1 and 3 sleeve type linear ball bearings	6
4.9 Flangeless shaft support blocks for series 1 and 3 sleeve type linear ball bearings	6
4.10 Solid and tubular shafts for series 1 and 3 sleeve type linear ball bearings	6
5 Housings.....	7
5.1 General.....	7
5.2 Housings for series 1 sleeve type linear ball bearings.....	7
5.3 Housings for series 3 sleeve type linear ball bearings.....	7
6 Shaft support rails	7
7 Shaft support blocks	7
8 Shafts	7
8.1 Material	7
8.2 Heat treatment.....	8
8.3 Geometrical tolerances	8
9 Boundary dimensions and tolerances	8
9.1 Housings.....	8
9.2 Shaft support rails	14
9.3 Shaft support blocks	16
9.4 Shafts	18

Foreword

ISO (the International Organization for Standardization) is a worldwide federation of national standards bodies (ISO member bodies). The work of preparing International Standards is normally carried out through ISO technical committees. Each member body interested in a subject for which a technical committee has been established has the right to be represented on that committee. International organizations, governmental and non-governmental, in liaison with ISO, also take part in the work. ISO collaborates closely with the International Electrotechnical Commission (IEC) on all matters of electrotechnical standardization.

International Standards are drafted in accordance with the rules given in the ISO/IEC Directives, Part 2.

The main task of technical committees is to prepare International Standards. Draft International Standards adopted by the technical committees are circulated to the member bodies for voting. Publication as an International Standard requires approval by at least 75 % of the member bodies casting a vote.

Attention is drawn to the possibility that some of the elements of this document may be the subject of patent rights. ISO shall not be held responsible for identifying any or all such patent rights.

ISO 13012-1 was prepared by Technical Committee ISO/TC 4, *Rolling bearings*, Subcommittee SC 11, *Linear motion rolling bearings*.

This first edition of ISO 13012-1 cancels and replaces ISO 13012:1998, which has been technically revised. It also incorporates the Technical Corrigendum, ISO 13012:1998/Cor.1:1999.

ISO 13012 consists of the following parts, under the general title *Rolling bearings — Accessories for sleeve type linear ball bearings*:

- *Part 1: Boundary dimensions and tolerances for series 1 and 3*
- *Part 2: Boundary dimensions and tolerances for series 5*

Introduction

The use of sleeve type linear ball bearings can be facilitated by the selection of bearing housings, shafts, shaft support blocks, and shaft support rails. These items, referred to as accessories, can aid in the application of the sleeve type linear ball bearings to achieve the desired criteria of smooth, accurate, low friction linear motion free from chatter or stick-slip.

The appropriate selection of bearing housing type, shaft, and shaft support should be established between the manufacturer and the user.

This part of ISO 13012 was developed to be used with ISO 10285.

Rolling bearings — Accessories for sleeve type linear ball bearings —

Part 1: Boundary dimensions and tolerances for series 1 and 3

1 Scope

This part of ISO 13012 specifies the boundary dimensions, other relevant dimensions and their tolerances of accessories for sleeve type linear ball bearings which are specified in ISO 10285.

This part of ISO 13012 applies to:

housings —

- closed and adjustable flangeless housings for series 1 sleeve type linear ball bearings,
- closed and adjustable flanged housings for series 3 sleeve type linear ball bearings,
- open flanged housings for series 3 sleeve type linear ball bearings,
- closed and adjustable flangeless housings for series 3 sleeve type linear ball bearings,
- open and open adjustable flangeless housings for series 3 sleeve type linear ball bearings;

shaft support rails —

- standard height shaft support rails for series 3 sleeve type linear ball bearings,
- low height shaft support rails for series 3 sleeve type linear ball bearings;

shaft support blocks —

- flanged shaft support blocks for series 1 and 3 sleeve type linear ball bearings,
- flangeless shaft support blocks for series 1 and 3 sleeve type linear ball bearings;

shafts —

- solid and tubular shafts for series 1 and 3 sleeve type linear ball bearings.

2 Normative references

The following referenced documents are indispensable for the application of this document. For dated references, only the edition cited applies. For undated references, the latest edition of the referenced document (including any amendments) applies.

ISO 286-2, *ISO system of limits and fits — Part 2: Tables of standard tolerance grades and limit deviations for holes and shafts*

ISO 1132-1, *Rolling bearings — Tolerances — Part 1: Terms and definitions*

ISO 1302, *Geometrical Product Specifications (GPS) — Indication of surface texture in technical product documentation*

ISO 3754, *Steel — Determination of effective depth of hardening after flame or induction hardening*

ISO 5593, *Rolling bearings — Vocabulary*

ISO 10285:2007, *Rolling bearings — Sleeve type linear ball bearings — Boundary dimensions and tolerances*

ISO 15241, *Rolling bearings — Symbols for quantities*

ISO 24393, *Rolling bearings — Linear motion rolling bearings — Vocabulary*

3 Terms and definitions

For the purposes of this document, the terms and definitions given in ISO 1132-1, ISO 5593, ISO 10285, ISO 24393 and the following apply.

3.1 flangeless housing

⟨sleeve type linear ball bearing⟩ bearing housing which has a face with bolt holes or threaded holes for attachment to a support surface nominally parallel to the bearing axis

3.2 flanged housing

⟨sleeve type linear ball bearing⟩ bearing housing which has a mounting face with projecting lugs having bolt holes for attachment to a support surface nominally parallel to the bearing axis

3.3 closed housing

⟨sleeve type linear ball bearing⟩ bearing housing in which the bearing seating is circumferentially continuous

3.4 adjustable housing

⟨sleeve type linear ball bearing⟩ bearing housing with a longitudinal slit across its bearing seating which facilitates the mechanical adjustment of the bearing seating diameter

3.5 open housing

⟨sleeve type linear ball bearing⟩ bearing housing with a longitudinal section removed to provide clearance over a shaft and support rail unit

3.6 open adjustable housing

⟨sleeve type linear ball bearing⟩ bearing housing which has the features of both open and adjustable sleeve type linear ball bearing housings

3.7 shaft support rail

longitudinal pedestal which provides continuous support to a shaft

NOTE Shaft support rails may be used with open sleeve type linear ball bearings.

3.8 shaft support block

block which provides support to a shaft

NOTE Shaft support blocks are normally used to support the shaft at its ends and can be used with closed sleeve type, adjustable sleeve type or open sleeve type linear ball bearings.

3.9

shaft

basically cylindrical rod along which a linear ball bearing traverses.

4 Symbols

For the purposes of this document, the symbols given in ISO 15241 and the following apply.

The symbols (except those for tolerances) shown in Figures 1 to 10, and the values given in Tables 1 to 11, denote nominal dimensions unless specified otherwise.

NOTE Figures 1 to 10 are drawn schematically and do not necessarily show all design details.

4.1 Closed and adjustable flangeless housings for series 1 sleeve type linear ball bearings

See Table 1 and Figure 1.

A (overall) width

D_a seating diameter

F_w bore diameter of ball complement of sleeve type linear ball bearing (reference)

G designation of screw thread of attachment hole

H distance from mounting face to centreline of seating diameter

H_1 (overall) height

J centre distance between mounting bolt holes (length)

L length of housing

N diameter of bolt hole

4.2 Closed and adjustable flanged housings for series 3 sleeve type linear ball bearings

See Table 2 and Figure 2.

A (overall) width

A_1 width of seating

D_a seating diameter

F_w bore diameter of ball complement of sleeve type linear ball bearing (reference)

H distance from mounting face to centreline of seating diameter

H_1 height of flange

H_2 (overall) height

J centre distance between bolt holes (length)

J_1 centre distance between bolt holes (width)

L length of housing

N diameter of bolt hole

4.3 Open flanged housings for series 3 sleeve type linear ball bearings

See Table 3 and Figure 3.

- A (overall) width
- A_1 width of seating
- D_a seating diameter
- E width of sector opening (at diameter D_a)
- F_w bore diameter of ball complement of sleeve type linear ball bearing (reference)
- H distance from mounting face to centreline of seating diameter
- H_1 height of flange
- H_2 (overall) height
- J centre distance between bolt holes (length)
- J_1 centre distance between bolt holes (width)
- L length of housing
- N diameter of bolt hole
- α angle of sector opening

4.4 Closed and adjustable flangeless housings for series 3 sleeve type linear ball bearings

See Table 4 and Figure 4.

- A (overall) width
- D_a seating diameter
- F_w bore diameter of ball complement of sleeve type linear ball bearing (reference)
- G designation of screw thread of attachment hole
- H distance from mounting face to centreline of seating diameter
- H_1 (overall) height
- J centre distance between bolt holes (length)
- J_1 centre distance between bolt holes (width)
- L length of housing
- L_1 distance from side face to centreline of seating diameter
- N diameter of bolt hole

4.5 Open and open adjustable flangeless housings for series 3 sleeve type linear ball bearings

See Table 5 and Figure 5.

- A (overall) width
- D_a seating diameter
- E width of sector opening (at diameter D_a)

F_w	bore diameter of ball complement of sleeve type linear ball bearing (reference)
G	designation of screw thread of attachment hole
H	distance from mounting face to centreline of seating diameter
H_1	(overall) height
J	centre distance between bolt holes (length)
J_1	centre distance between bolt holes (width)
L	length of housing
L_1	distance from side face to centreline of seating diameter
N	diameter of bolt hole
α	angle of sector opening

4.6 Standard height shaft support rails for series 3 sleeve type linear ball bearings

See Table 6 and Figure 6.

A	(overall) width
d	outside diameter of shaft (reference)
H	distance from mounting face to centreline of shaft
H_1	height of flange
J	centre distance between bolt holes (length)
J_1	centre distance between bolt holes (width)
M	width of shaft support
N	diameter of bolt hole
N_1	diameter of bolt hole (shaft attachment)

4.7 Low height shaft support rails for series 3 sleeve type linear ball bearings

See Table 7 and Figure 7.

A	(overall) width
d	outside diameter of shaft (reference)
H	distance from mounting face to centreline of shaft
H_1	height of flange
H_2	distance from mounting face to top of attachment screw head
J	centre distance between bolt holes (length)
J_1	centre distance between bolt holes (width)
M	width of shaft support
N	diameter of bolt hole
N_1	diameter of bolt hole (shaft attachment)
β	angle of shaft support

4.8 Flanged shaft support blocks for series 1 and 3 sleeve type linear ball bearings

See Table 8 and Figure 8.

- A (overall) width
- D_a seating diameter
- H distance from mounting face to centreline of seating diameter
- H_1 height of flange
- H_2 (overall) height
- J centre distance between bolt holes (length)
- L length of base
- N diameter of bolt hole

4.9 Flangeless shaft support blocks for series 1 and 3 sleeve type linear ball bearings

See Table 9 and Figure 9.

- A (overall) width
- D_a seating diameter
- G designation of screw thread of attachment hole
- H distance from mounting face to centreline of seating diameter
- H_1 (overall) height
- J centre distance between bolt holes
- L length of base
- N diameter of bolt hole

4.10 Solid and tubular shafts for series 1 and 3 sleeve type linear ball bearings

See Tables 10 and 11, and Figure 10.

- d outside diameter of shaft
- d_s single outside diameter of shaft
- L length of shaft
- L_s actual length of shaft
- t straightness of shaft
- V_{dmp} variation of mean outside diameter of shaft
- V_{dsp} variation of outside diameter of shaft in a single plane
- Δ_{ds} deviation of a single outside diameter of shaft
- Δ_{Ls} deviation of the actual length of shaft

5 Housings

5.1 General

To facilitate the design and assembly of sleeve type linear ball bearings, specifically designed housings are available. Included in this part of ISO 13012 are the boundary dimensions and other related dimensions of sleeve type linear ball bearings series 1 and 3 as specified in ISO 10285:2007.

The housings specified in Tables 1 to 5 and the corresponding sleeve type linear ball bearings should be supplied by the same producer. The reason for this is that the fixation of the bearings in the housings is specified by the producer and is not covered by this part of ISO 13012.

5.2 Housings for series 1 sleeve type linear ball bearings

This part of ISO 13012 includes the following housing design for series 1 sleeve type linear ball bearings:

- closed and adjustable flangeless housings (Table 1).

5.3 Housings for series 3 sleeve type linear ball bearings

This part of ISO 13012 includes the following housing designs for series 3 sleeve type linear ball bearings:

- closed and adjustable flanged housings (Table 2);
- open flanged housings (Table 3);
- closed and adjustable flangeless housings (Table 4);
- open and open adjustable flangeless housings (Table 5).

6 Shaft support rails

This part of ISO 13012 includes the following shaft support rails for sleeve type linear ball bearings:

- standard height shaft support rails for series 3 sleeve type linear ball bearings (Table 6);
- low height shaft support rails for series 3 sleeve type linear ball bearings (Table 7).

7 Shaft support blocks

This part of ISO 13012 includes the following shaft support blocks for sleeve type linear ball bearings:

- flanged shaft support blocks for series 1 and 3 sleeve type linear ball bearings (Table 8);
- flangeless shaft support blocks for series 1 and 3 sleeve type linear ball bearings (Table 9).

8 Shafts

8.1 Material

Shafts covered by this part of ISO 13012 are precision hardened and ground steel shafts in both solid and tubular section. They are manufactured from high quality carbon steel or high quality carbon chrome steel and are either surface hardened or through hardened.

8.2 Heat treatment

8.2.1 Surface hardened shafts

The cylindrical surface of the shafts is heat treated to provide a basically uniform effective depth of hardening and a surface hardness of not less than 653 HV (58 HRC) over the entire operating length. The effective depth of hardening shall be determined in accordance with ISO 3754. This effective depth of hardening is the distance from the outside surface of the shaft to a material layer at which the hardness is approximately 80 % of the specified minimum surface hardness. End faces of shafts may remain unhardened.

8.2.2 Through hardened shafts

The shafts shall be heat treated to give a surface hardness of no less than 653 HV (58 HRC) over the entire operating length.

8.3 Geometrical tolerances

8.3.1 Tolerance classes

The precision hardened and ground solid and tubular shafts are specified in two diameter tolerance classes to match the sleeve type linear ball bearing and housing series.

8.3.2 Geometric form

The geometric form of each tolerance class is controlled by the following features:

- a) circularity (roundness): variation of shaft outside diameter in a single plane;
- b) cylindricity (taper, concavity, convexity): variation of mean shaft outside diameter;
- c) straightness (per metre).

These tolerances for both classes are shown in Table 10. A method for measuring straightness is illustrated in Figure 10 and defined in Table 10.

8.3.3 Shaft length tolerances

These tolerances are given in Table 11.

8.3.4 Chamfers

The shaft ends are provided with chamfers to facilitate entry of the shaft into the sleeve type linear ball bearing. The ends of shafts with machined end faces are usually provided with chamfers that are shallow in the radial direction and long in the axial direction. The length of the chamfer is shown in Table 10. Shafts for use with sealed sleeve type linear ball bearings shall have a chamfer angle less than 30°.

8.3.5 Surface roughness

The roughness of the cylindrical surface of the steel shaft is given in Table 10 in accordance with ISO 1302.

9 Boundary dimensions and tolerances

9.1 Housings

Boundary dimensions and tolerances for housings are given in Tables 1 to 5.

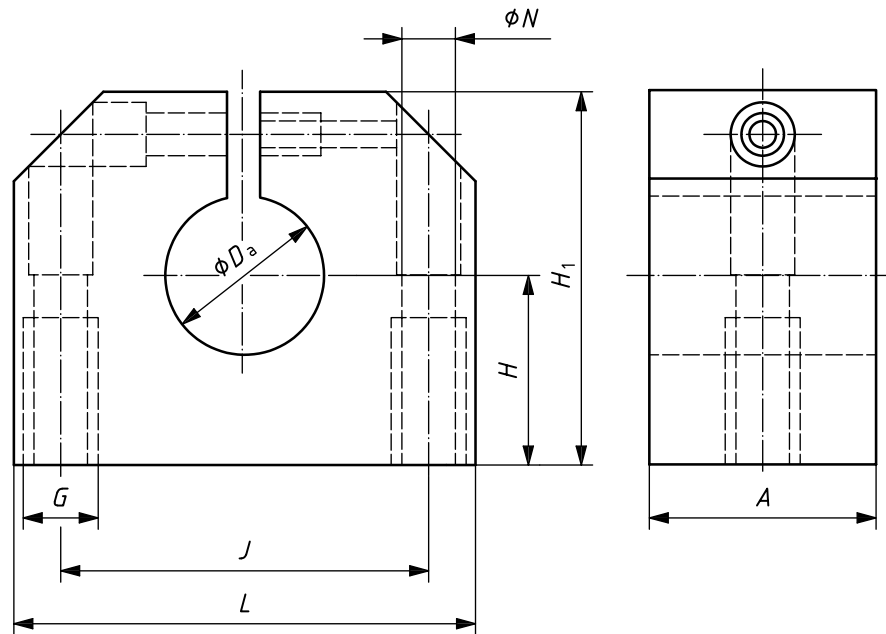

NOTE This figure shows an adjustable type housing.

Figure 1 — Closed and adjustable flangeless housings for series 1 sleeve type linear ball bearings

Table 1 — Closed and adjustable flangeless housings for series 1 sleeve type linear ball bearings

Dimensions in millimetres

F_w Ref.	D_a K7 ^a or H7 ^b	H^c $\pm 0,02$	H_1 max.	L max.	A max.	J	N	G
3	7	10	18	26	11	16	2,7	M3
4	8	11	20	27	13	17	2,7	M3
5	10	12	22	28	16	18	2,7	M3
6	12	14	26	32	20	22	3,4	M4
8	15	15	29	35	25	25	3,4	M4
10	17	16	32	39	27	27	4,3	M5
12	19	17	34	41	29	29	4,3	M5
14	21	18	39	46	29	34	4,3	M5
16	24	19	39	46	31	34	4,3	M5
20	28	23	46	54	31	40	5,3	M6
25	35	27	55	63	41	48	6,6	M8
30	40	30	61	68	51	53	6,6	M8
40	52	39	77	88	61	69	8,4	M10
50	62	47	93	104	71	82	10,5	M12
60	75	57	113	122	86	100	10,5	M12

^a Seating diameter tolerance for aluminium housings for closed type bearings (see ISO 286-2).

^b Seating diameter tolerance for steel or aluminium housings for adjustable type bearings and for steel housings for closed type bearings (see ISO 286-2).

^c The dimension H shall be measured with the nominal seating bore diameter. For adjustable type housings, the tolerance for D_a shall apply before the housing is split.

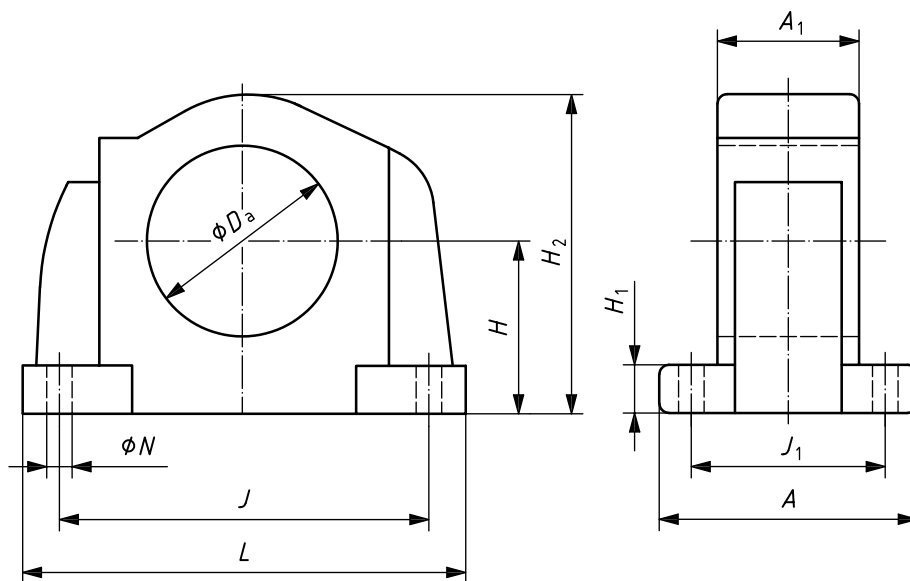

NOTE This figure shows a closed type housing.

Figure 2 — Closed and adjustable flanged housings for series 3 sleeve type linear ball bearings

Table 2 — Closed and adjustable flanged housings for series 3 sleeve type linear ball bearings

Dimensions in millimetres

F_w Ref.	D_a H7 ^a	H^b $\pm 0,02$	H_1 max.	H_2 max.	L max.	A max.	A_1		J	J_1	N
							max.	min.			
5	12	11	4	22	33	25	12,1	11,7	24	16	3,4
6	13	12	5	24	34	26	12,1	11,7	25	18	3,4
8	16	15	6	29	46	29	14,1	13,7	25	20	3,4
10	19	17	6	30	50	30	20,1	19,7	34	21	4,5
12	22	18	7	36	54	33	20,1	19,7	32	23	4,5
16	26	22	8	43	58	36	22,1	21,7	40	26	4,5
20	32	25	9	51	72	43	28,1	27,7	45	32	4,5
25	40	30	10	62	82	56	40,1	39,6	60	40	5,5
30	47	35	11	72	90	62	48,1	47,5	68	45	6,6
35	52	40	12	80	96	68	45,1	44,5	76	50	6,6
40	62	45	13	92	110	80	56,1	55,5	86	58	9
50	75	50	15	107	137	72	72,1	71,5	108	50	9
60	90	60	18	131	162	94	95,1	94,5	132	65	11
80	120	80	23	176	207	124	125,1	124,5	170	90	13,5
100	150	100	30	210	250	135	135,1	134,5	210	100	17,5

^a Seating diameter tolerance (see ISO 286-2).

^b The dimension H shall be measured with the nominal seating bore diameter. For adjustable type housings, the tolerance for D_a shall apply before the housing is split.

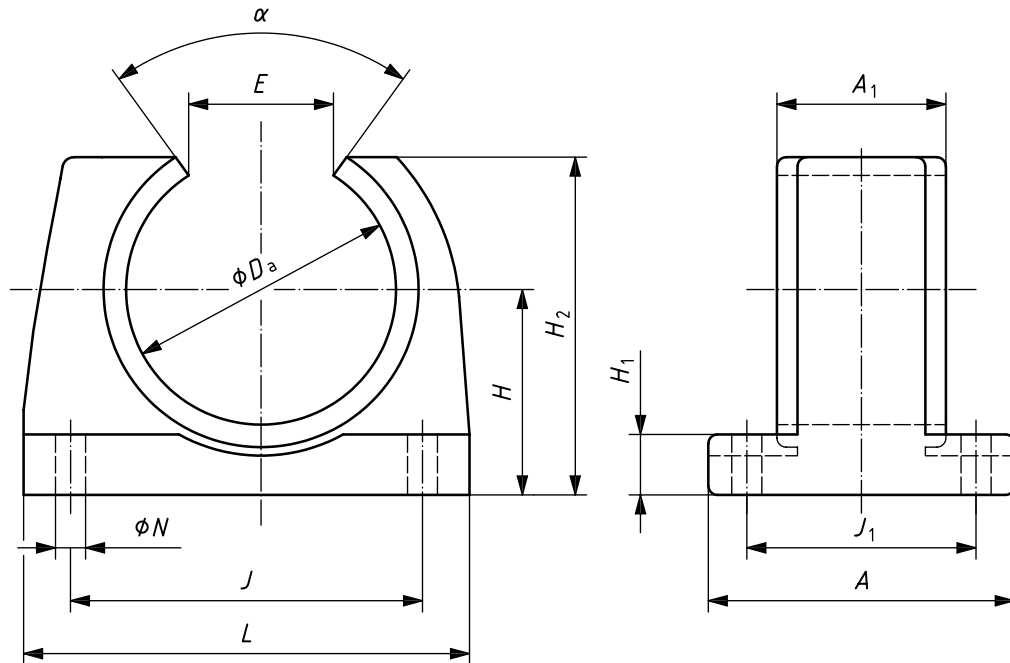

Figure 3 — Open flanged housings for series 3 sleeve type linear ball bearings

Table 3 — Open flanged housings for series 3 sleeve type linear ball bearings

Dimensions in millimetres and angles in degrees

F_w	D_a^a	H^c	H_1	H_2	L	A	A_1		J	J_1	N	α	E
Ref.	JS7 ^b	$\pm 0,02$	max.	max.	max.	max.	max.	min.				min.	min.
10	19	17	6	27	50	30	20,1	19,7	32	21	4,5	65	11
12	22	18	7	29	54	33	20,1	19,7	32	23	4,5	65	12
16	26	22	8	36	58	36	22,1	21,7	40	26	4,5	50	13,5
20	32	25	9	43	72	43	28,1	27,7	45	32	4,5	50	14,5
25	40	30	10	52,5	82	56	40,1	39,6	60	40	5,5	50	17,5
30	47	35	11	61,5	90	62	48,1	47,5	68	45	6,6	50	20
35	52	40	12	69	96	68	45,1	44,5	76	50	6,6	50	22
40	62	45	13	78,5	110	80	56,1	55,5	86	58	9	50	26
50	75	50	15	89,5	137	72	72,1	71,5	108	50	9	50	32
60	90	60	18	106,5	162	94	95,1	94,5	132	65	11	50	39
80	120	80	23	141,5	207	124	125,1	124,5	170	90	13,5	50	53
100	150	100	30	177	250	135	135,1	134,5	210	100	17,5	50	66

^a Diameter D_a can only be measured when the housing is fastened to a plane surface.

^b Seating diameter tolerance (see ISO 286-2).

^c The dimension H shall be measured with the nominal seating bore diameter.

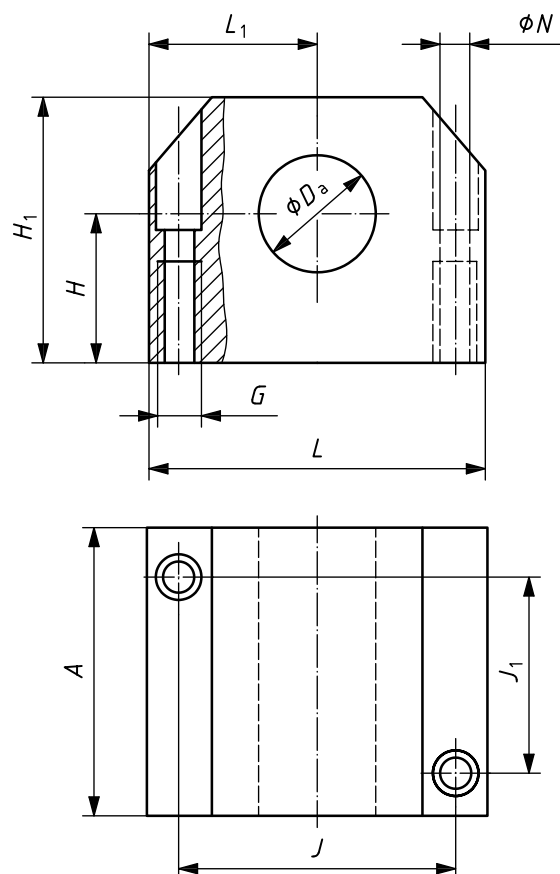

NOTE 1 Alternatively, there can be four attachment holes.

NOTE 2 This figure shows a closed type housing.

Figure 4 — Closed and adjustable flangeless housings for series 3 sleeve type linear ball bearings

Table 4 — Closed and adjustable flangeless housings for series 3 sleeve type linear ball bearings

Dimensions in millimetres

F_w Ref.	D_a^a H7 ^b	H^c $\pm 0,02$	H_1 max.	L max.	L_1 $\pm 0,02$	A max.	J	J_1	N	G
10	19	16	32	40	20	37	29	20	4,3	M5
12	22	18	36	43	21,5	40	32	23	4,3	M5
16	26	22	43	53	26,5	44	40	26	5,3	M6
20	32	25	51	60	30	56	45	32	6,6	M8
25	40	30	62	78	39	69	60	40	8,4	M10
30	47	35	72	87	43,5	81	68	45	8,4	M10
40	62	45	92	108	54	93	86	58	10,5	M12
50	75	50	107	132	66	115	108	50	13,5	M16

^a For adjustable type housings, D_a can only be measured when the housing is fastened to a plane surface.

^b Seating diameter tolerance (see ISO 286-2).

^c The dimension H shall be measured with the nominal seating bore diameter. For adjustable type housings the tolerance for D_a shall apply before the housing is split.

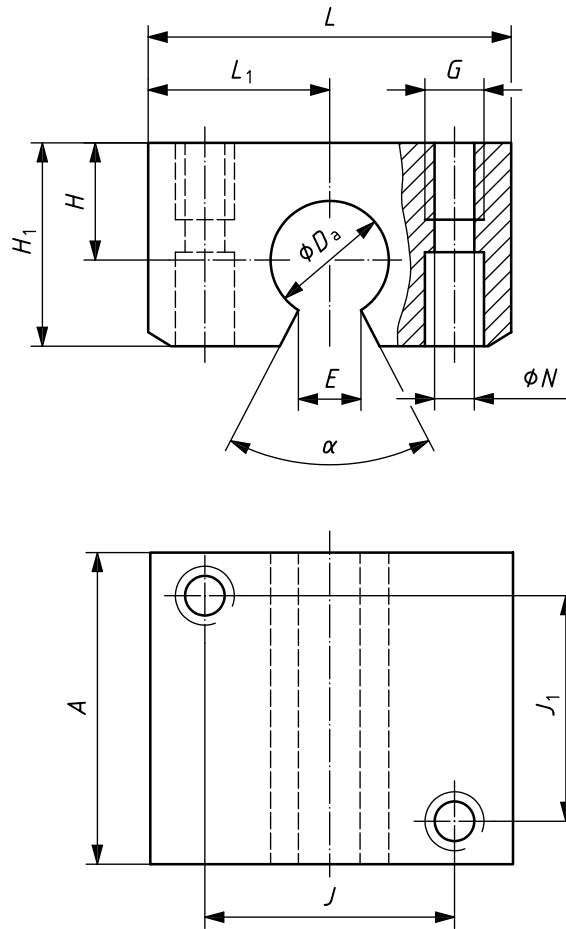

NOTE 1 Alternatively, there can be four attachment holes.

NOTE 2 This figure shows an open type housing.

Figure 5 — Open and open adjustable flangeless housings for series 3 sleeve type linear ball bearings

Table 5 — Open and open adjustable flangeless housings for series 3 sleeve type linear ball bearings

Dimensions in millimetres and angles in degrees

F_w Ref.	D_a^a JS7 ^b	H^c $\pm 0,02$	H_1 max.	L max.	L_1 $\pm 0,02$	A max.	J	J_1	N	G	α min.	E min.
12	22	18	29	43	21,5	40	32	23	4,3	M5	65	12
16	26	22	36	53	26,5	44	40	26	5,3	M6	50	13,5
20	32	25	43	60	30	56	45	32	6,6	M8	50	14,5
25	40	30	52,5	78	39	69	60	40	8,4	M10	50	17,5
30	47	35	61,5	87	43,5	81	68	45	8,4	M10	50	20
40	62	45	78,5	108	54	93	86	58	10,5	M12	50	26
50	75	50	89,5	132	66	115	108	50	13,5	M16	50	32

^a Diameter D_a can only be measured when the housing is fastened to a plane surface.

^b Seating diameter tolerance (see ISO 286-2).

^c The dimension H shall be measured with the nominal seating bore diameter.

9.2 Shaft support rails

Boundary dimensions are given in Tables 6 and 7.

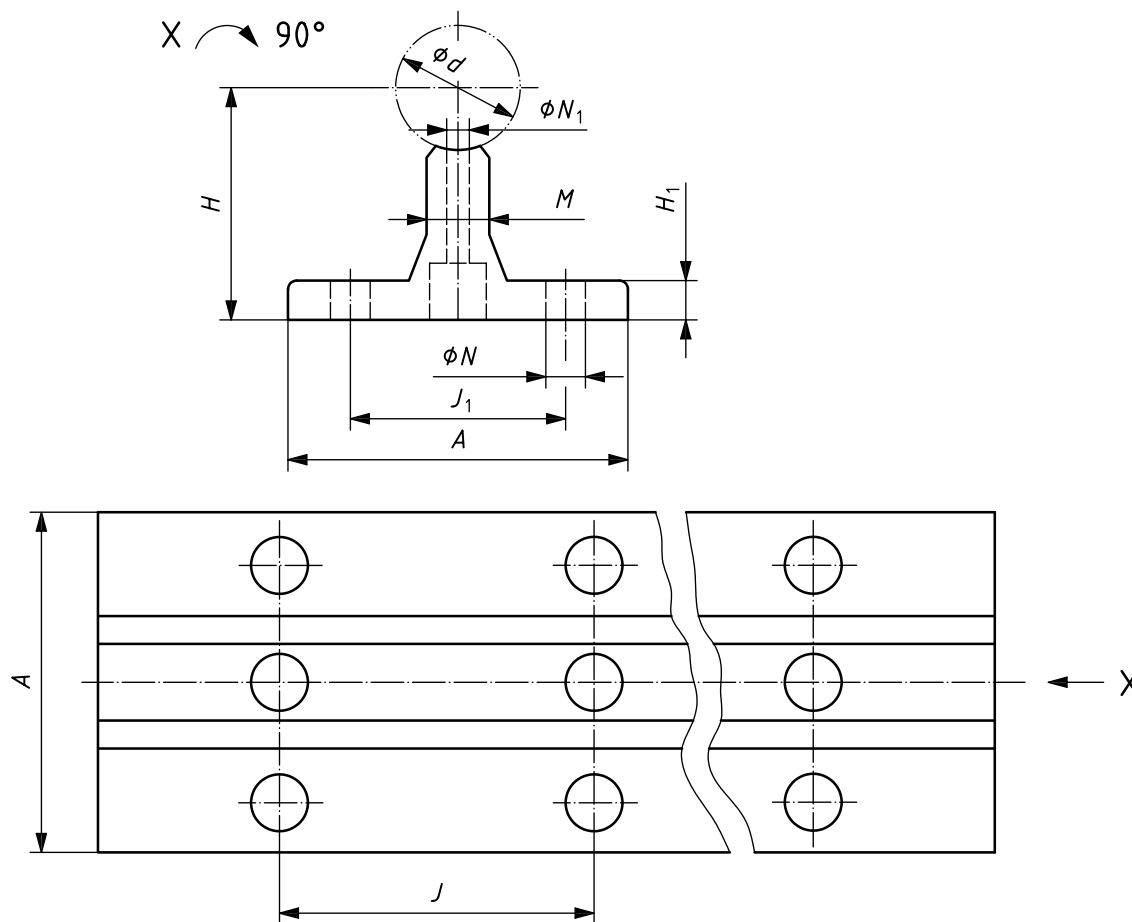

Figure 6 — Standard height shaft support rails for series 3 sleeve type linear ball bearings

Table 6 — Standard height shaft support rails for series 3 sleeve type linear ball bearings

Dimensions in millimetres

d Ref.	H^a $\pm 0,02$	J_1	J	N	N_1	A	H_1	M
10	25	27	75	3,4	4,5	40	5	8
12	28	29	75	4,5	4,5	43	5	9
16	30	33	100	5,5	5,5	48	5	10
20	38	37	100	6,6	6,6	56	6	11
25	42	42	120	6,6	9	60	6	14
30	53	51	150	9	11	74	8	14
35	55	53	200	9	11	76	8	16
40	60	55	200	9	11	78	8	18
50	75	63	200	11	13,5	90	10	22
60	80	72	300	11	15,5	100	12	30
80	100	92	300	13,5	17,5	125	14	42
100	120	112	300	17,5	22	160	16	55

^a The dimension H shall be measured with the nominal shaft diameter under mounting condition.

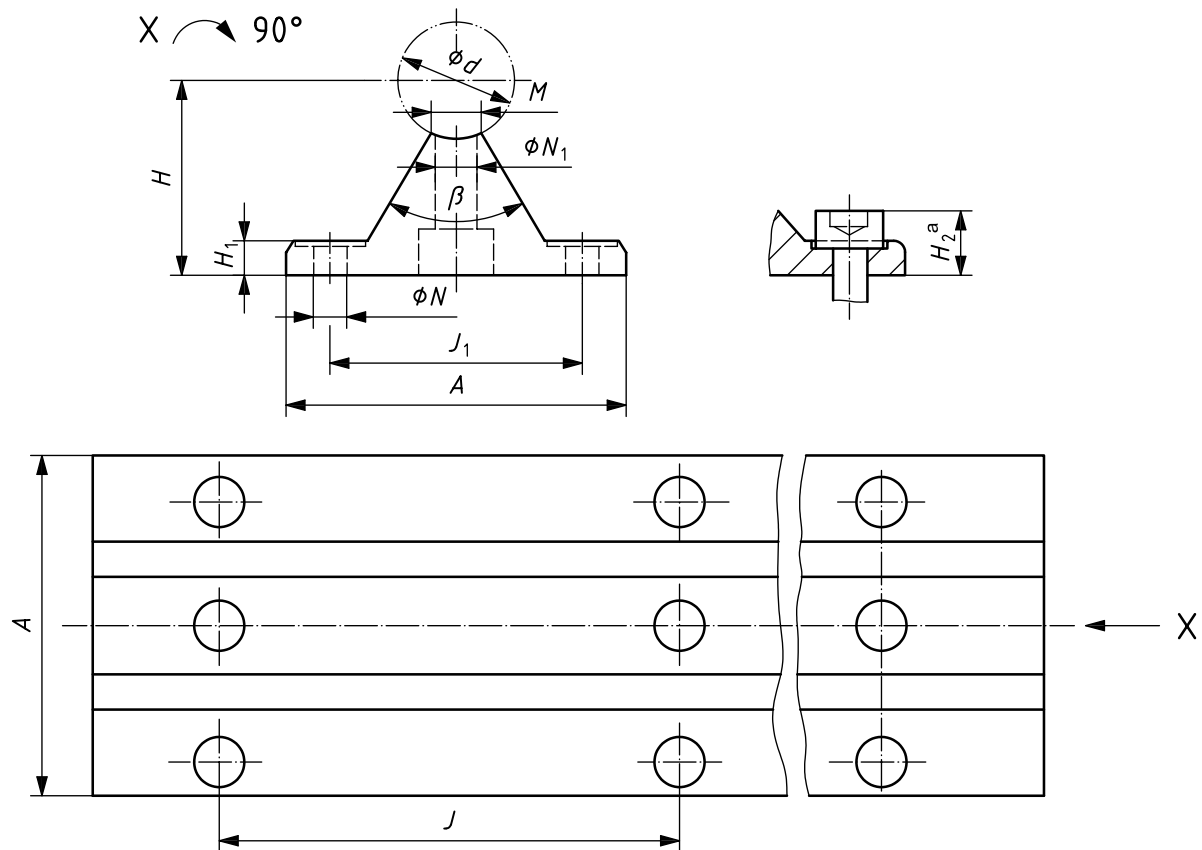

^a As an option, use shallow head hexagonal socket head cap screws or counterbore the flange to comply with H_2 max.

Figure 7 — Low height shaft support rails for series 3 sleeve type linear ball bearings

Table 7 — Low height shaft support rails for series 3 sleeve type linear ball bearings

Dimensions in millimetres and angles in degrees

d	H^a	A	H_1	H_2	J_1	J	M	N	N_1	β
Ref.	$\pm 0,02$	max.	$\pm 0,5$	max.			max.			max.
10	20	35	4	8	25	75	4,7	4,5	4,5	50
12	22	40	5	10	29	75	5,8	4,5	4,5	50
16	26	45	5	11	33	100	7	5,5	5,5	50
20	32	52	6	13	37	100	8,3	6,6	6,6	50
25	36	57	6	13	42	120	10,8	6,6	9	50
30	42	69	7	15	51	150	11	9	11	50
35	46	69	8	16	51	200	13	9	11	50
40	50	73	8	16	55	200	15	9	11	50
50	60	84	9	20	63	200	19	11	13,5	46
60	68	94	10	21	72	300	25	11	15,5	46
80	86	116	12	24	92	300	34	13,5	17,5	46
100	110	146	15	31	126	300	45	17,5	22	46

^a The dimension H shall be measured with the nominal shaft diameter under mounting condition.

9.3 Shaft support blocks

Boundary dimensions are given in Tables 8 and 9.

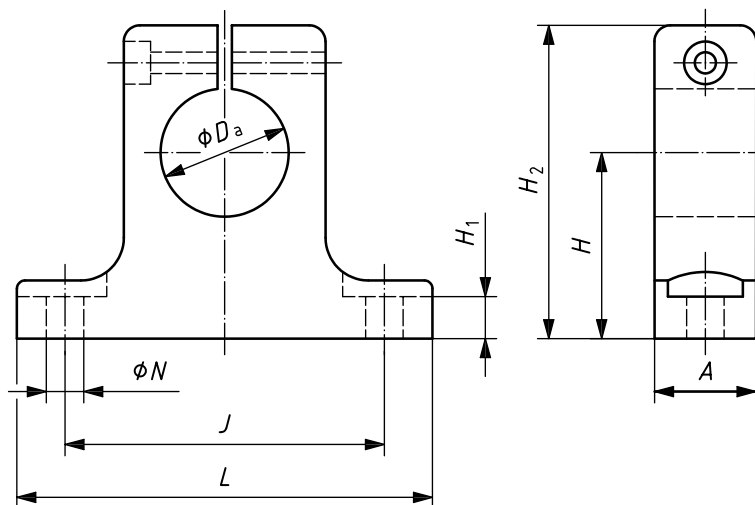

Figure 8 — Flanged shaft support blocks for series 1 and 3 sleeve type linear ball bearings

Table 8 — Flanged shaft support blocks for series 1 and 3 sleeve type linear ball bearings

Dimensions in millimetres

D_a H8 ^a	H^b $\pm 0,02$	A max.	J	N	L max.	H_1 max.	H_2 max.
5	13	9	20	3,4	32	5	24
6	14	11	23	4,5	32	5,5	27,5
8	15	11	25	4,5	46	5,5	28
10	17	11	28	4,5	50	5,5	30,5
12	20	13	32	5,5	54	5,5	36
14	22	15	36	5,5	56	6	39
16	25	17	40	5,5	58	6,5	43
20	30	21	45	5,5	72	8	51
25	35	29	60	6,6	82	9	61
30	40	31	68	9	90	10	71
35	45	32	74	9	100	12	82
40	50	37	86	11	110	12	91
50	60	50	108	11	137	14	106
60	75	63	132	13,5	162	15	131
80	100	86	170	17,5	207	22	176
100	125	80	200	22	250	30	200

^a Seating diameter tolerance (see ISO 286-2). The tolerance shall apply before the support block is split.

^b The dimension H shall be measured with the nominal seating bore diameter.

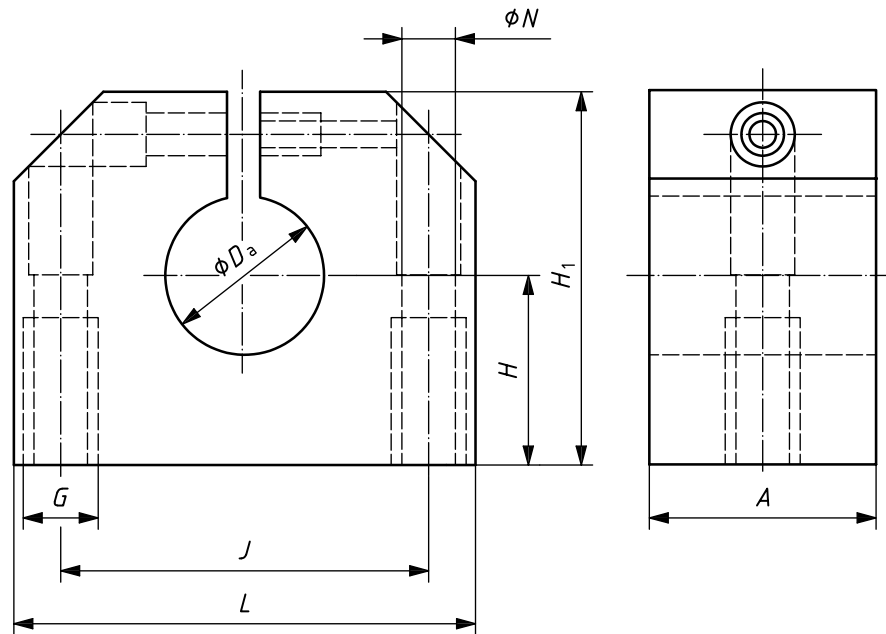

Figure 9 — Flangeless shaft support blocks for series 1 and 3 sleeve type linear ball bearings

Table 9 — Flangeless shaft support blocks for series 1 and 3 sleeve type linear ball bearings

Dimensions in millimetres

D_a H8 ^a	L max.	A max.	H^b $\pm 0,02$	H_1 max.	J	N	G
10	40	21	18	32	27	5,3	M6
12	43	21	20	36	30	5,3	M6
16	53	25	25	43	38	6,6	M8
20	60	31	30	52	42	8,4	M10
25	78	39	35	62	56	10,5	M12
30	87	41	40	71	64	10,5	M12
40	108	49	50	90	82	13,5	M16
50	132	59	60	106	100	17,5	M20

^a Seating bore diameter tolerance (see ISO 286-2). The tolerance shall apply before the support block is split.

^b The dimension H shall be measured with the nominal seating bore diameter.

9.4 Shafts

Boundary dimensions and tolerances are given in Tables 10 and 11.

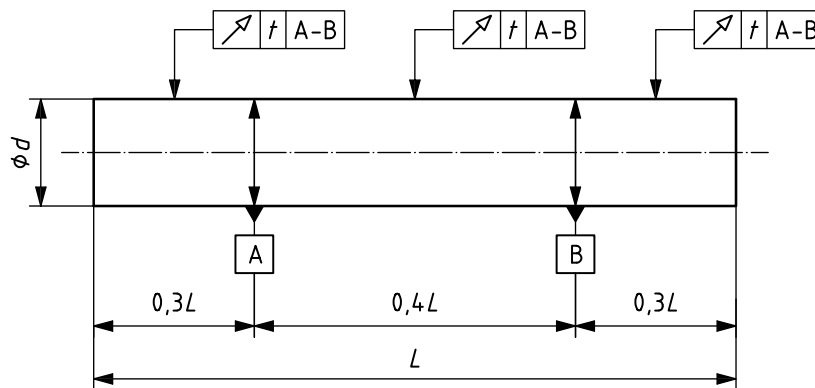

Figure 10 — Solid and tubular shafts for series 1 and 3 sleeve type linear ball bearings

Table 10 — Solid and tubular shafts for series 1 and 3 sleeve type linear ball bearings

<i>d</i> mm	Δ_{ds}				V_{dsp}		V_{dmp}		<i>t</i> Straightness ^a µm/m max.	Surface roughness <i>Ra</i> µm max.	Effective depth of hardening ^b mm min.	Length of chamfer mm min.
	Class h6		Class h7		Class h6	Class h7	Class h6	Class h7				
	µm high	µm low	µm high	µm low	µm max.	µm max.	µm max.	µm max.				
3	0	-6	0	-10	3	4	4	6	150	0,32	0,4	0,8
4	0	-8	0	-12	4	5	5	8	150	0,32	0,4	0,8
5	0	-8	0	-12	4	5	5	8	150	0,32	0,4	1
6	0	-8	0	-12	4	5	5	8	150	0,32	0,4	1
8	0	-9	0	-15	4	6	6	9	120	0,32	0,4	1
10	0	-9	0	-15	4	6	6	9	120	0,32	0,4	1
12	0	-11	0	-18	5	8	8	11	100	0,32	0,6	1,5
14	0	-11	0	-18	5	8	8	11	120	0,32	0,6	1,5
16	0	-11	0	-18	5	8	8	11	100	0,32	0,6	1,5
20	0	-13	0	-21	6	9	9	13	100	0,32	0,9	1,5
25	0	-13	0	-21	6	9	9	13	100	0,32	0,9	1,5
30	0	-13	0	-21	6	9	9	13	100	0,32	0,9	1,5
35	0	-16	0	-25	7	11	11	16	100	0,32	1,5	2,5
40	0	-16	0	-25	7	11	11	16	100	0,32	1,5	2,5
50	0	-16	0	-25	7	11	11	16	100	0,32	1,5	2,5
60	0	-19	0	-30	8	13	13	19	100	0,32	2,2	2,5
80	0	-19	0	-30	8	13	13	19	100	0,32	2,2	2,5
100	0	-22	0	-35	10	15	15	22	100	0,32	3,2	3,5

NOTE These shafts are only suitable for use in combination with sleeve type linear ball bearings of series 1 and 3 as specified in ISO 10285:2007.

^a Straightness specifications measured as in Figure 10. Measurements are taken at points equidistant between support points and overhanging ends of the shaft. A shaft, when supported as shown and rotated through 360° shall not cause a total indicator reading (TIR) in excess of the straightness tolerance stated above. The TIR values given by this measurement method are double the real shaft straightness tolerance values.

^b For surface hardened shafts.

Table 11 — Shaft length tolerances for series 1 and 3

Dimensions and tolerance values in millimetres

<i>L</i>		Δ_{Ls}	
>	≤	high	low
30	120	+0,3	-0,3
120	400	+0,5	-0,5
400	1 000	+0,8	-0,8
1 000	2 000	+1,2	-1,2
2 000	4 000	+2	-2
4 000	8 000	+3	-3

BSI - British Standards Institution

BSI is the independent national body responsible for preparing British Standards. It presents the UK view on standards in Europe and at the international level. It is incorporated by Royal Charter.

Revisions

British Standards are updated by amendment or revision. Users of British Standards should make sure that they possess the latest amendments or editions.

It is the constant aim of BSI to improve the quality of our products and services. We would be grateful if anyone finding an inaccuracy or ambiguity while using this British Standard would inform the Secretary of the technical committee responsible, the identity of which can be found on the inside front cover. Tel: +44 (0)20 8996 9000. Fax: +44 (0)20 8996 7400.

BSI offers members an individual updating service called PLUS which ensures that subscribers automatically receive the latest editions of standards.

Buying standards

Orders for all BSI, international and foreign standards publications should be addressed to Customer Services. Tel: +44 (0)20 8996 9001. Fax: +44 (0)20 8996 7001 Email: orders@bsigroup.com You may also buy directly using a debit/credit card from the BSI Shop on the Website <http://www.bsigroup.com/shop>

In response to orders for international standards, it is BSI policy to supply the BSI implementation of those that have been published as British Standards, unless otherwise requested.

Information on standards

BSI provides a wide range of information on national, European and international standards through its Library and its Technical Help to Exporters Service. Various BSI electronic information services are also available which give details on all its products and services. Contact Information Centre. Tel: +44 (0)20 8996 7111 Fax: +44 (0)20 8996 7048 Email: info@bsigroup.com

Subscribing members of BSI are kept up to date with standards developments and receive substantial discounts on the purchase price of standards. For details of these and other benefits contact Membership Administration. Tel: +44 (0)20 8996 7002 Fax: +44 (0)20 8996 7001 Email: membership@bsigroup.com

Information regarding online access to British Standards via British Standards Online can be found at <http://www.bsigroup.com/BSOL>

Further information about BSI is available on the BSI website at <http://www.bsigroup.com>

Copyright

Copyright subsists in all BSI publications. BSI also holds the copyright, in the UK, of the publications of the international standardization bodies. Except as permitted under the Copyright, Designs and Patents Act 1988 no extract may be reproduced, stored in a retrieval system or transmitted in any form or by any means – electronic, photocopying, recording or otherwise – without prior written permission from BSI.

This does not preclude the free use, in the course of implementing the standard, of necessary details such as symbols, and size, type or grade designations. If these details are to be used for any other purpose than implementation then the prior written permission of BSI must be obtained.

Details and advice can be obtained from the Copyright and Licensing Manager. Tel: +44 (0)20 8996 7070 Email: copyright@bsigroup.com